

Main specification parameter for Track Roller

Brand	Model	Product Name	Part Number	Assembly Quantity	Weight
Caterpillar	390D	Track Roller Caterpillar	1855065	1	164.2kg

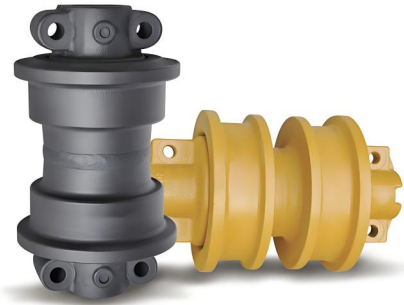

Assembly Compatible Equipment Models:1855065

365B	365B II	365B II	365C	365C L
375-A	385B	385B	385C	385C L
385C FS	385C L MH	385C L MH	390D	390D L
5080	5090B	5090B		

Product Details

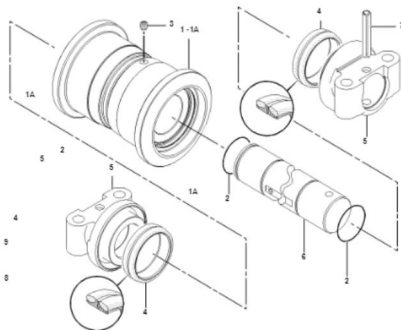
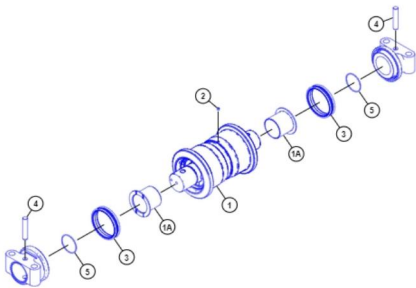

Product Name	Cat 374 Bottom Track Rollers
Part Number	5337368
Diameter	304mm
Track pitch	260.4mm
Type	Single flange
Origin	United States
Model	374
Quality Assurance	6-12 Month
Price	Negotiable
Brand Name	STONE
Packing Details	Standard Export Packing
Delivery Time	0-30 Days
Payment Term	L/C, T/T
Price Term	FOB, CIF, CFR
Supply Capacity	1000 PCS/Month
Minimum Order Quantity	1 PC
Material	High Quality Steel
Technology	Precision Machining
Surface	Treatment Anti-Corrosion Coating
Quality	Original Factory Standard
After-Sales Service	Full Support, Online Service
Color	Standard Caterpillar Yellow or Customizable
Application	Excavator
Customizable	including customized materials, surface treatment and specifications

Track Roller Caterpillar

1855065

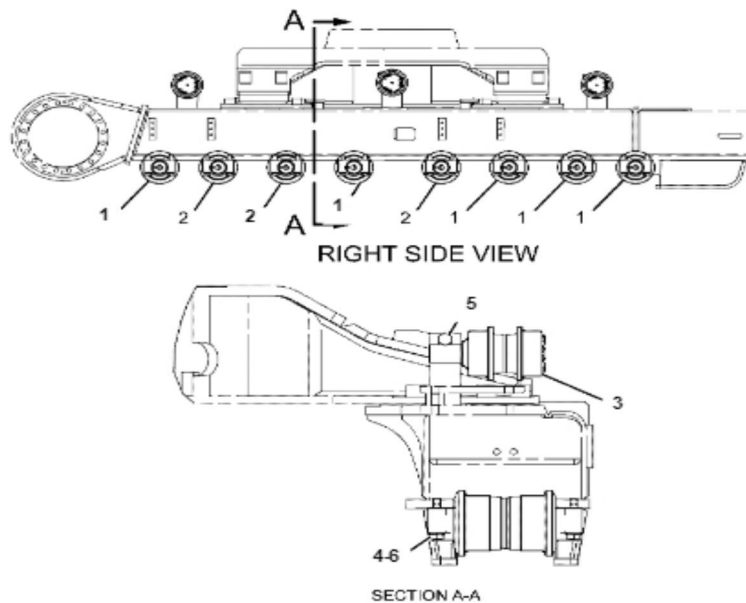

STONE: Construction machinery parts expert in China



We are committed to providing a variety of parts including bulldozers, excavators and wheel loaders for well-known brands such as Carter and Komatsu. Our product line covers a full range of OEM parts, such as Track Chain, Track Rollers, Sprocket, Excavator Buckets, Blades, Excavator Cylinders, Swing Circles, and various electrical and hydraulic components to ensure that our customers' stringent requirements for quality and performance are met.



Stone (Shanghai) Engineering Machinery Co., Ltd. is a leading supplier of engineering machinery parts, focusing on providing high-quality parts for mining companies. Since its establishment in 2004, we have been based in Shanghai, China, and have built our own brand STONE, becoming a trusted choice in the industry.

Stone (Shanghai) Engineering Machinery Co., Ltd
sale@shmpine.com [whatsapp:+8613671661119](https://www.whatsapp.com/+8613671661119)